

Bats In and Around Your Home

Rebecca McPeake
 Extension Specialist -
 Wildlife

Blake Sasse
 Nongame Mammal
 Program Coordinator,
 Arkansas Game and
 Fish Commission

David A. Saugey
 Wildlife Biologist,
 U.S. Forest Service,
 Ouachita National Forest

Few wildlife species elicit such a range of reactions and emotions as bats (Figure 1). Bats are feared by some, while others are captivated by these unusual and often misunderstood creatures of the night.

Bats are our only true flying mammals. They emit high frequency sounds that bounce back as echoes from objects and prey in their environment. This echolocation enables bats to fly in darkness and detect insects that are usually caught while in flight. Studies of little brown bats (*Myotis lucifugus*) indicate they catch and eat 500 to 1,200 mosquitoes and other tiny insects an hour. A colony of 150 big brown bats (*Eptesicus fuscus*) in one summer ate an estimated 38,000 cucumber beetles, 16,000 June bugs, 19,000 stinkbugs and 50,000 leafhoppers, which are all major crop pests. A bat colony can assist farmers who want to use a natural, biological method of insect control.

Bats are beneficial in other ways, too. Bat guano (droppings) is processed for organic gardening. Its contents are roughly 10 percent nitrogen, 3 percent phosphorous and 1 percent potassium plus trace elements that contribute to rapid plant growth. Some homeowners contend these nutrients remain in the soil longer than chemical fertilizers that can leach out of the soil soon after application.



Figure 1. The Rafinesque's big-eared bat (*Corynorhinus rafinesquii*) is one of the least known of all bats and inhabits most of Arkansas.

David A. Saugey

Arkansas is home to 16 species of bats. State law protects all bat species, but the federally endangered Indiana bat (*Myotis sodalis*), gray bat (*Myotis grisescens*) and Ozark big-eared bat (*Corynorhinus townsendii ingens*) receive additional state and federal protection. It is illegal to kill, harm, harass or possess these endangered mammals. All three endangered species hibernate in caves in the Ozarks during the winter months, and the gray and big-eared bats use caves to raise their young during spring and summer. Disturbance by humans during these sensitive times has caused population declines over the last 25 years.

If you own a bat cave and would like additional information about protecting bats, contact the Arkansas Game and Fish Commission (501-223-6300) and speak with the private lands biologist in your area. Funds may be available for constructing specially-designed gates at cave entrances that allow bats to enter and exit while protecting them from predators and people.

*Arkansas Is
 Our Campus*

Visit our web site at:
<http://www.uaex.edu>

Bat Control

Bats can be beneficial, but it's not a good idea to have them in your living quarters. If a bat enters your home, simply turn off the lights, open a few doors or windows leading to the outside and allow the bat to leave on its own. Chasing or swatting bats causes undue panic for the flying mammals and people alike. If opening windows and doors doesn't do the trick, the bat can be caught in a butterfly net. Always wear thick leather gloves when you are netting or capturing a bat. If the bat is resting on a wall or curtain, place a coffee can or large bowl slowly over it while sliding a piece of cardboard between the bat and the wall. The bat should be released in an elevated position such as on a tree branch or wall. Unlike birds, bats have to drop and catch air under their wings before they can fly.

If a bat colony is in an occupied building or home (Figure 2), you will need to seal entrances into your living space. Some people decide to let a small colony remain in attics or under eaves. Additional measures may not be necessary unless bat droppings become a problem or there is a concern about bats coming into direct contact with people or pets. If you decide to remove the bat colony, you will need to develop a plan for excluding bats without trapping them within the structure. For difficult problems, hiring a professional wildlife nuisance control operator is advisable.



Figure 2. A big brown bat maternity colony in the attic of a home.

David A. Saugey

If you need to clean your attic after relocating a bat colony, sprinkle diatomaceous earth in the roost area to eliminate any parasites that remain. Thoroughly spray bat droppings with water to reduce the amount of dust and prevent spreading spores from *Histoplasma capsulatum* which can cause histoplasmosis. Histoplasmosis is an infectious, non-contagious disease which originates from a fungus that lives in bat and bird droppings. Exposure to this fungus is widespread in Arkansas, although the vast majority of infected people have no ill effects. Some may require medical attention for respiratory

problems which develop 3 to 17 days after exposure. If large amounts of bat droppings are to be removed, take precautions against inhaling airborne particles. Use a respirator mask that filters particles of two microns in diameter or smaller. For more information, refer to the Extension publication *Histoplasmosis Control*, MP 268.

Bats and Rabies

Rabies is the most important public health hazard associated with bats, although the incidence of transmission is very rare. Bat Conservation International reports that more humans die annually from being attacked by domestic dogs than from encounters with bats. Despite this low incidence, a sick bat is a risk for rabies and should be avoided. Sick bats are active during the daytime or are found on the ground, incapable of flying. A bat found on the ground is not necessarily rabid, but don't tempt bats by touching them, as bats are more likely to bite if touched. If bitten or scratched by a bat, wash the affected area with soap and water, and seek immediate medical attention. Try capturing the bat without damaging its head, so that it can be tested for rabies. Modern treatment for rabies is normally safe, relatively painless and very effective. A lack of treatment can result in death, so get prompt treatment after exposure.

Bat-Proofing Your Home

The ultimate bat control technique is preventing their entry into the home. The best time for bat-proofing is in the spring before bats enter the roost or in the fall after young bats leave. Bat-proofing should never be attempted from May through August when the youngsters are in the roost. Bat-proofing at this time could lead to health risks and odor problems, not to mention ethics and the legality of harming and killing bats, as the young bats will die and decay. You will need to carefully evaluate your situation and develop a strategy, perhaps using several of the bat-proofing techniques described below.

- **Seal entrances.** With as little as a 3/8-inch wide crack, bats can gain entry through an open window, an unscreened chimney, a gap in an outside wall, roof overhangs, loose vents, openings where electrical wire boxes or water pipes enter the house or openings between drop siding. Once bats are evicted, screen or tape their entrances, plug holes with steel wool or a copper mesh or gauze and fill cracks with expanding foam insulation or caulking. To observe where bats are entering or exiting, station several people around the building about 30 minutes before dark or one hour before dawn so that all sides can be seen. Watch for about an hour, noting where the bats are flying in or out.

If no bats are seen, try another evening when the weather conditions are different. Observers should be as quiet as possible. A flashlight can be used, but direct the main part of the beam away from where bats are exiting, as this may cause them to stay inside the building.

- **Install one-way doors.** Do not use one-way doors from May through August when flightless young bats are present. You can make your own one-way door from heavy plastic, bird netting or wire screening (Figure 3). If using plastic or bird netting, make a strip at least two feet wide and extend it at least two feet below where bats exit. The material should be stapled or taped several inches above the exit. Let the remaining material hang about a foot to each side and below the exit. The bats should have enough space to drop down and exit but will be unable to fly up and reenter the building. Another alternative is to use 1/4- to 1/2-inch wire screening or plastic mesh to cover the exit. The screening should cover the width of the hole and extend approximately 3 feet below the hole, so the bat can crawl down the screening and exit from the bottom. The screening can be secured to the building with tape or staples. Remove the one-way door after three or four days and seal the opening.

Figure 3. One-way doors allow bats to exit a building but prevent their reentry.

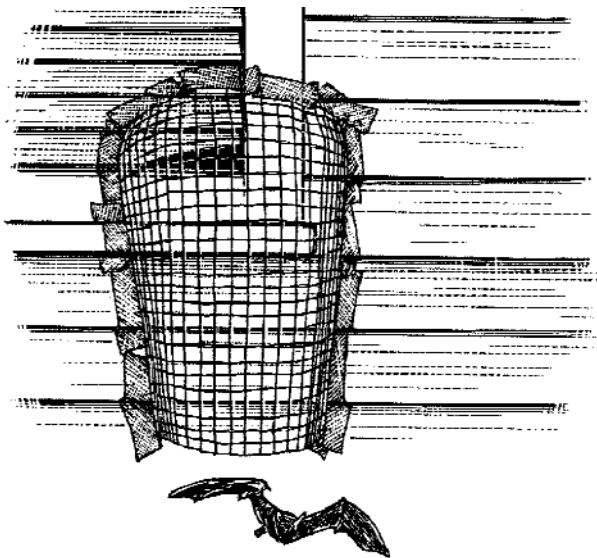

This illustration is from *A Homeowner's Guide to Northeastern Bats and Bat Problems* by the Pennsylvania State University, College of Agricultural Sciences, Cooperative Extension.

- **Polypropylene bird netting.** Netting for excluding birds from agricultural crops and fruit trees may also be a practical exclusion device for bats in some situations. The netting can be draped over parts of a building in April or May when the bats begin arriving, then removed and stored until the next spring. Check local markets for bat netting products sold in self-contained kits.

Implementing multiple techniques is the best approach to bat-proofing your home. When young bats are **not** present, seal all but a few bat entrances and install one-way doors in the remaining entrances. This will allow bats to leave but not return.

Consider installing alternative housing for bats. Once bats are excluded, they have to find somewhere else to live or they will die. In one instance, bats that had lived in an attic before bat-proofing began roosting under the eaves near their old exit. A bat box was installed and the bats took residence in this alternative structure. Ideally, bats should be allowed to investigate a new bat house well in advance of bat-proofing a building in the fall. It is best if a standard bat box can be installed near the bats' entry to the building. Bats are very loyal to traditional roosting sites. By providing a bat box, those returning in the spring may be less inclined to find another entry into the building where they previously roosted.

Design and Placement of Bat Boxes

Bat houses are available commercially or can be constructed at home using **untreated** plywood and/or cedar. Placement of boxes is critical for attracting bats. A well-designed bat house may attract few bats without a water source, such as a creek or lake, within 1/4 mile. Also, the height and temperature of the box are key factors for determining whether bats will occupy the box. For those interested in building a bat box, two types are a standard bat box and a post bat house design.

Standard bat box. A standard bat box (Figure 4) should be placed 15 to 20 feet above ground, either on a pole or the side of a wood or stone building. Less preferable are boxes in tall trees. Bat houses should receive six to ten hours of sunlight in the summer. Maternity colonies require box temperatures of 80 to 95 degrees for their young. The lower portion of the box can be vented, allowing bats to cool themselves when temperatures become too hot. Houses on poles can be protected from overheating with tin roofs and overhanging eaves that shield the top of the box. Exterior seams should be caulked. The interior structure contains baffles dividing the interior space into multiple roosting crevices, 3/4 inch in depth. Boxes with long roosting chambers tend to have higher occupancy rates than smaller, stacked boxes. The roosting partitions should be rough cut or covered with 3/4 inch plastic (not metal) screening to provide bats with footholds. Screening can also be added to the landing area along the bottom of the back board. Slots located on the front and sides of the box provide air ventilation. A new box should be stored outside so that the scent of new materials is weathered. This type of bat house can house up to about 300 bats.

Figure 4. Plans for building a standard bat box.

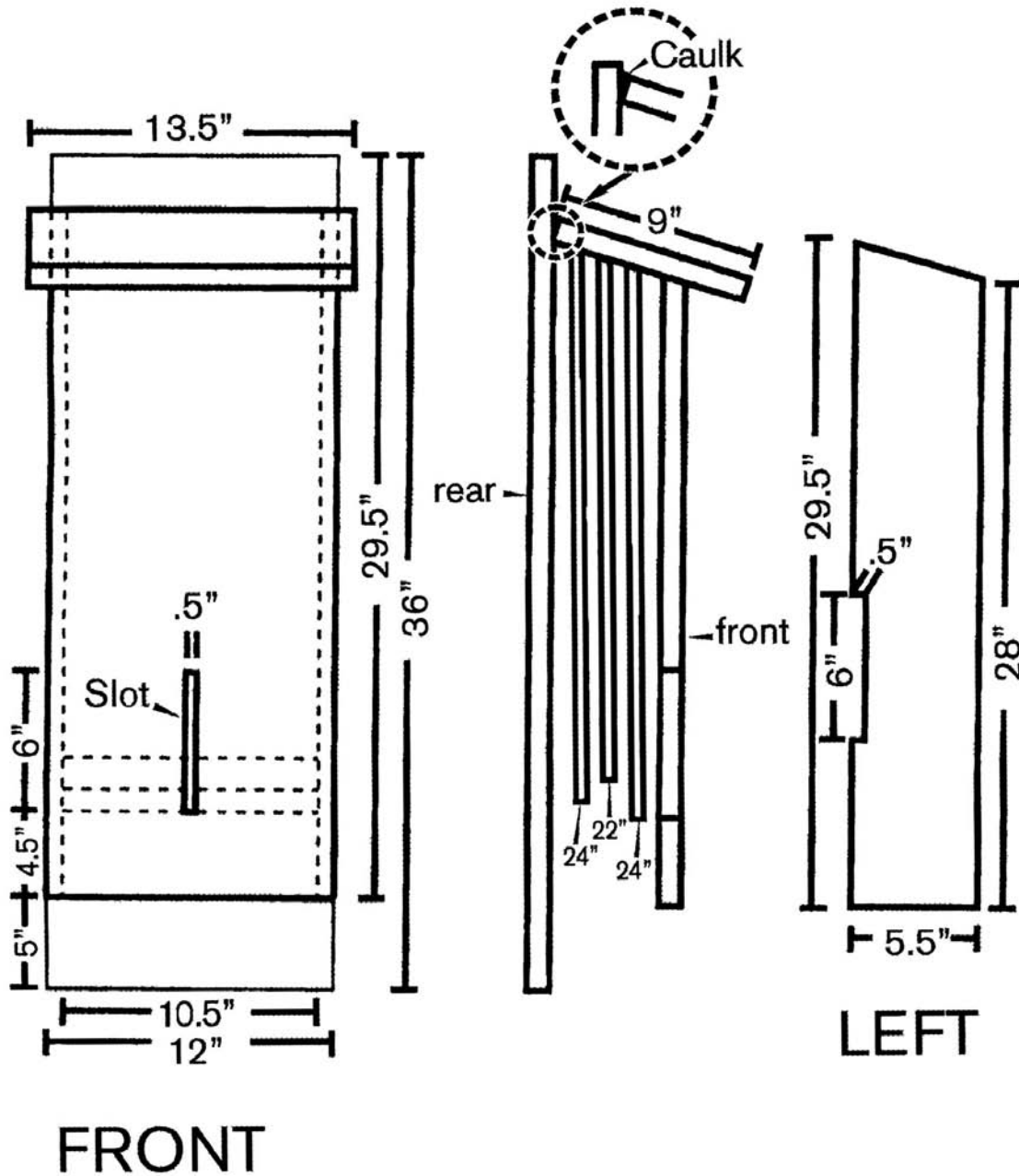

Post bat house. A post bat house or rocket box design (Figure 5) is more like a natural summer roost for bat species that live under tree bark. Bats can move freely to the warmer or cooler sides of the box to adjust for temperature changes throughout the day. The best wood for the 20-foot mounting post is oak, red cedar or black locust. Western red cedar is readily available at home improvement stores. The box itself can be made of lighter wood since it will not contact the ground and is covered by a roof. Another option is to use a metal mounting post for the bat house, though the interior of the bat box (that is mounted on the metal pole) needs to extend 6 to 12 inches below the outer box to provide a landing area for bats. When building the bat box,

turn the "rough" side of lumber to the inside for a good roosting surface. Measure the outer box carefully to allow only a 3/4-inch entry into the box. Use only galvanized screws to put the box together. Place the post at least 2 1/2 to 3 feet in the ground; if unable to do so, set the post in cement. The post bat house is more suited for forested areas away from houses, barns and outbuildings. These houses should be located in either (1) upland forest habitats on south or southwest slopes in a place where there is no tree canopy, (2) small openings near ponds, streams or other water, (3) along forest roads or right-of-ways for powerlines, pipelines or waterlines or (4) between forests and clearcuts or along the edges of forest gaps.

Figure 5. Plans for building a post bat house.

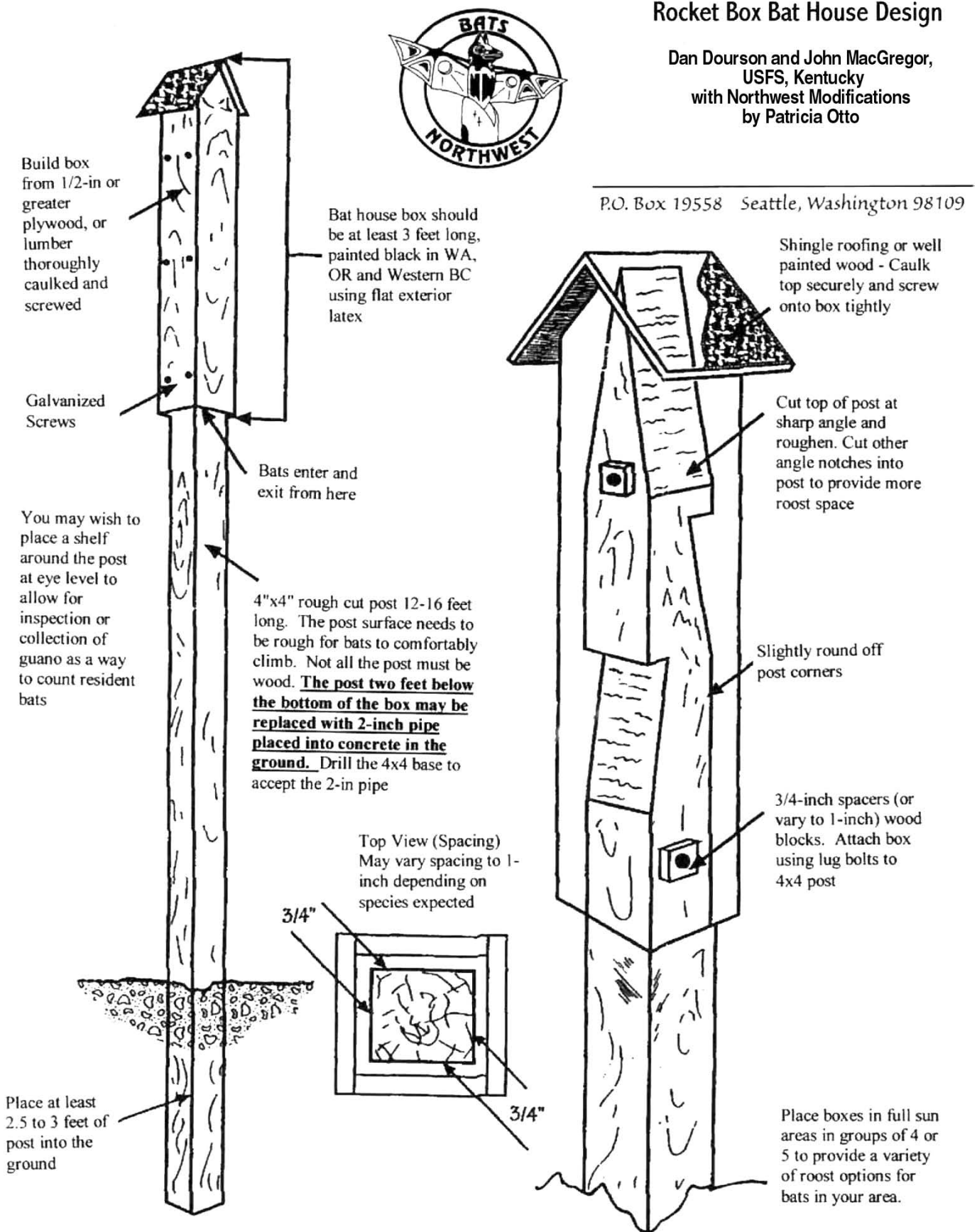

A study of occupancy rates of standard bat houses near homes found the majority of boxes were occupied within the first year. To check for bat use without disturbing the house or its occupants, take an aluminum pie pan, cut out a space in the center and fit it around your support post. Bat droppings will collect in the pan and let you know if you have residents. Boards can be placed on the ground to collect droppings, but ants may carry them away if you don't check early in the morning. Bat droppings look like mouse droppings (i.e., small cylinders with points on the end) but have a twisted appearance. When teased apart, moth scales and other insect parts will be observed. If you think you have bats, sit out at dusk and watch them leave the box to confirm. If a bat box hasn't been occupied after two seasons, consider moving the box to another location. Never give up and remove the bat box entirely, however, as even unoccupied boxes can serve in an emergency for a stray bat or colony that lost its roosting site.

Bat boxes should not be disturbed once bats arrive. Do not illuminate bat houses with bright lights. In urban settings, the area below the box can be fenced or shrubs planted to prevent disturbance. A predator guard, such as wrapping a post with sheet metal, may be necessary to keep out snakes and other climbing critters. The box's design with spacings no more than 3/4 inch will make it less attractive to wasps and mud daubers. However, if found, active wasp nests should be removed without using chemicals and repairs made to the box after bats leave in the fall and winter.

Resources

Whether you wish to attract bats near your home or prefer to keep them at a distance, they are undeniably a unique wildlife resource in Arkansas.

For a color version of this fact sheet, see our Extension web site at www.uaex.edu/Other_Areas/publications/HTML/FSA-9088.asp.

Check the Arkansas Game and Fish Commission's web site for more information about Arkansas bats (www.agfc.state.ar.us) or call (501-223-6300) and order *Woodworking for Wildlife* for other wildlife structures.

Bat Conservation International (www.batcon.org) is an organization dedicated to preserving bats and their habitats through partnerships with government agencies, research and education. BCI Publications include *BATS* magazine, *The Bat House Builder's Handbook* and educators' packages about bats (1-800-538-BATS). A web version of *Bats of Eastern Forests* can be found at BCI's web site at <http://www.batcon.org/nabcp/newsite/forests.html>. This handbook contains an abundance of information on bat species and management concerns.

Another excellent resource is the Organization for Bat Conservation (517-339-5200, www.batconservation.org) which offers a number of educational materials and information about bats and bat house designs.

DR. REBECCA McPEAKE is Extension specialist - wildlife, University of Arkansas Cooperative Extension Service, Little Rock. **BLAKE SASSE** is the nongame mammal program coordinator, Arkansas Game and Fish Commission, Little Rock. **DAVID A. SAUGEY** is a wildlife biologist, U.S. Forest Service, Ouachita National Forest.

FSA9088-PD-9-02N

Issued in furtherance of Cooperative Extension work, Acts of May 8 and June 30, 1914, in cooperation with the U.S. Department of Agriculture, Director, Cooperative Extension Service, University of Arkansas. The Arkansas Cooperative Extension Service offers its programs to all eligible persons regardless of race, color, national origin, religion, gender, age, disability, marital or veteran status, or any other legally protected status, and is an Equal Opportunity Employer.